

VISION

# Orange 1021 ig 10 Pan Full Size

ig - Advanced injection gas (Boilerless)

Default configuration: G20 natural gas, type A3 (flue gas ventilation into the working area), optional flue gas exhaust type B13 (stack exhaust) or type B23 (stack exhaust without gas cooling).



## UNIQUE BENEFITS



### Vision Perfect Cooking

Make your diners great reason to keep returning to your place. With Retigo Vision combi ovens, you have the peace of mind that you will always achieve outstanding cooking results. The prepared foods have a perfect colour, are juicy, crispy and healthy with a minimal fat contain.



### Vision Design

Simply keeps you cooking with ease and comfort. Experience an excellent combination of features, exceptional ergonomics and attractive appearance. All this with a focus on safety, hygiene and long time reliability.



### Vision Controls

Gives you time to concentrate on cooking and things that really matter to you. The simplest controls on the market will save you time and enable you to quickly and easily make all the necessary settings. Panel response is perfect even with grease or gloved hands.



### Smart Investment

Generates money on savings for you every day. In-built heat exchanger, triple glazed door glass, 2" thick thermoinsulation combined with low consumption automatic cleaning will ensure you great return on investment.

retigo® PERFECTION IN COOKING AND MORE...

RETIGO USA, Inc.  
600 Eagleview Blvd., Suite 300, Exton, PA 19341  
retigoUSA@retigo.us, www.retigo.us

Certified by:



\* DVGW and WRAS certificates are valid for models with retractable hand shower only.

# FEATURES & BENEFITS

## Cooking

- **Hot air** 86 – 572 °F
- **Combination** 86 – 572 °F
- **Steaming** 86 – 266 °F
- **Bio steaming** 86 – 208 °F
- **Over night cooking** – Saves time and money.
- **Advanced steam generation system** – Two-step water preheating with in-built heat exchanger for perfect steam cooking results.
- **Crosswise racks** – Safer and comfortable pans handling. Better product visual control.
- **Regeneration/banqueting** – Cook, chill and regenerate to serve more diners in shorter times.
- **Low temperature cooking** – Benefit from less weight loss, better taste.
- **Automatic preheating/cooling** minimises the loading temperature drop. Start cooking with the desired temperature.

## Vision Controls

- **Touch panel** – Fast controls covered by high protective foil . Gives immediate reaction on commands, makes panel seamless and easy to clean.
- **Continuous cooking time option** - Saves your time during busy operations.
- **Automatic start** – The ability to schedule a delayed start.

## Other equipment

- **Active Cleaning** – Low-cost automatic cleaning. No chef's time spent on cleaning any more.
- **Triple glazed door glass** - Advanced energy savings and external glass that does not burn you.
- **7 Fan speeds** – Precise control of air distribution for desired results with different products.
- **Automatic Fan stop** – No scalding when the door opened quickly.
- **Auto-reversing fan** – Excellent evenness to deliver high product color and texture uniformity.
- **Massive door handle** – Comfortable and safe handling with silver ion material contain for bacteria reduction.
- **AISI 304 and 316 stainless steel** – Exceptional quality with a special coating for a extended life time.
- **Hygienic cooking chamber with round inner corners** – Trouble free maintenance.
- **Run-off tray under the door** – No slipping on wet floor.
- **Two water inlets** – Saves a water treatment unit's capacity.
- **WSS (Water Saving System)** – Special drain system & in-built heat exchanger to save water related cost.
- **Removable pans holders** with 2.9" spacing

## Conectivity

- **USB plug-in** – Transfer useful data easily to and from the combi oven.
- **VisionCombi software** – Program and pictogram management in your PC, HACCP data view.

## Operation logs

- **HACCP records** – Easy and immediate analysis of critical cooking points.
- **Complete operating records**

## Service

- **SDS (Service Diagnostic System)** – Easy unit check up and trouble shooting.

## Unit options

- Safety door opening in two steps

---

## Optional accessories

ST 621/1021 stand with 7 x Half-size & 7 x Full-size racks  
ST 621/1021 FP flat pack stand with 7 x Half-size & 7 x Full-size racks  
Cleaning chemicals

## TECHNICAL DATA

|                         |   |
|-------------------------|---|
| Model                   | O 1021 ig                                     |
| Technical specification | 2G1021IA                                      |
| Heat source             | Natural gas / Propane                         |
| Steam generator         | Advanced injection (Boilerless)               |
| Capacity                | 11 x Full-size or 22 x Half-size cooking pans |
| Capacity of meals       | 300 – 500                                     |
| Spacing                 | 2.9"  |
| Dimensions (w x h x d)  | 44.1" x 42.8" x 40.1"                         |
| Weight                  | 447.5 lbs                                     |
| Total power             | 0.9 kW  |
| Heat power              | 135,000 BTU/hr                                |
| Fuse protection         | 15 A  |
| Voltage                 | 3~/208 V/50-60Hz                              |
| Noise level             | max. 70 dBA                                   |
| Water/Drain connection  | G ¾" / 2"                                     |
| Gas connection          | NPT ¾"  |
| Temperature             | 86 – 572 °F                                   |

### STACKING OPTIONS

| Lower unit | Upper unit |
|------------|------------|
| 1021       | 621        |
| 1021       | 621 ig     |

### WATER QUALITY

It is the sole responsibility of the owner/operator/purchaser of this equipment to verify that the incoming water supply is comprehensively tested and if required, a means of "water treatment" provided that would meet compliance requirements with the water quality standards published below. Noncompliance with these minimum standards could potentially damage this equipment and/or components and VOID the original equipment manufacturer's warranty.

### WATER PARAMETERS

| Parameters             | Value                    |
|------------------------|--------------------------|
| Inlet pressure         | 2-6 bar (29-87,02 psi)   |
| Water Hardness (TH)    | ≤ 5°dH (< 90 ppm (mg/l)) |
| Total Dissolved Solids | 40 < 150 ppm (mg/l)      |
| pH                     | 7,0-8,5                  |
| Free chlorine          | <0.1 ppm (mg/l)          |
| Total chlorine         | < 0.1 ppm (mg/l)         |
| Chlorides              | < 40 ppm (mg/l)          |
| Total Chloramine       | < 0.1 ppm (mg/l)         |
| Iron                   | < 0.1 ppm (mg/l)         |
| Silica                 | < 13 ppm (mg/l)          |

# DRAWINGS

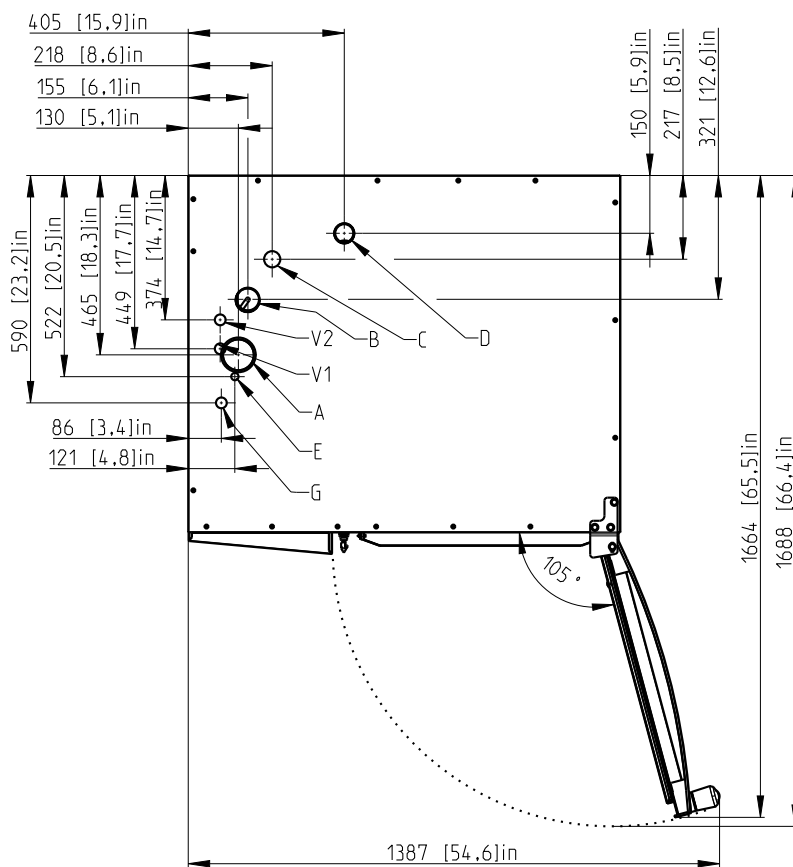
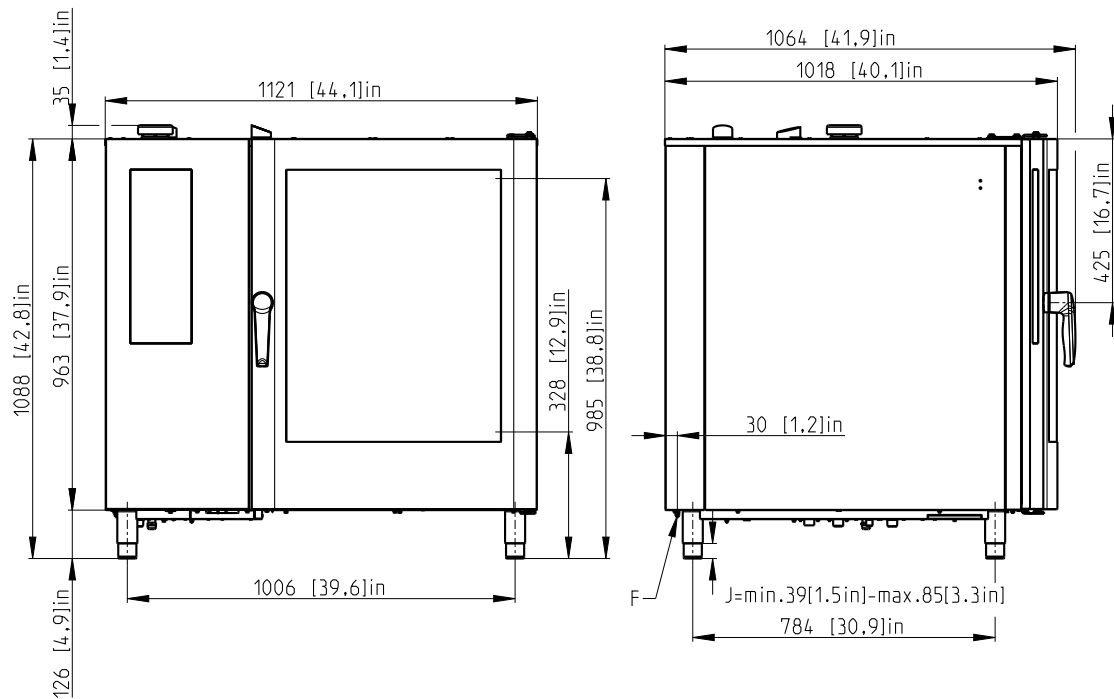

|    |                 |
|----|-----------------|
| A  | flap valve      |
| B  | chimney         |
| C  | waste           |
| E  | electricity     |
| G  | gas             |
| V1 | untreated water |
| V2 | treated water   |